



ROLTEX SOLIDORA CASSETTE FOLDING ARM AWNING SYSTEM

The compact multi award winning Roltex Solidora Cassette Folding Arm Awning System provides unparalleled technical strength for its class. German designed, engineered and manufactured, the Solidora will integrate efficiently into most contemporary building designs.

Protection

- The Roltex Solidora Cassette Folding Arm Awning offers complete protection against harsh ultra violet rays. With up to 5000mm coverage in width and 3000mm in projection. Our marine grade textiles offer the best compromise between visibility and light transmission, while providing incomparable weather resistance and ease of maintenance.

Functionality

- The Solidora has been designed and engineered utilising a two piece heavy-duty aluminium extrusion that provides maximum stability and protects all moving components. The Ergonomically designed cassette requires only one fixing bracket at each end of the awning.

Technology

- All components are manufactured from heavy-duty drop forged aluminium, our unique cassette utilises 6061 grade extruded aluminium, components are protected with a durable powder coat finish (Dulux Powder Coat Chart). The pitch of the awning is easily adjustable from the mounting pivot system located at each end of the awning.

Quality

- Designed, engineered and manufactured in Germany, Certified ISO 9001 and safety tested by German TUV Product Service. Roltex Solidora Cassette Folding Arm Awnings Systems are assembled under German quality guidelines and assembly processes in Australia. Tecnic offers our experienced network superior quality and service that you can rely on.



ROLTEX SOLIDORA CASSETTE FOLDING ARM AWNING

SPECIFICATIONS

Please note illustrations are not to scale. All measurements are in millimetres. Please contact your Tecnic representative for additional information.

FIXING METHODS

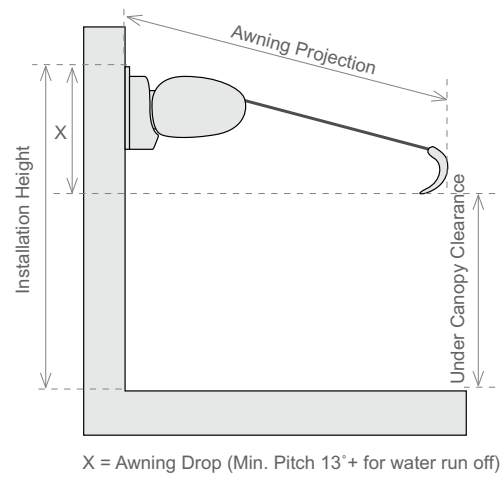
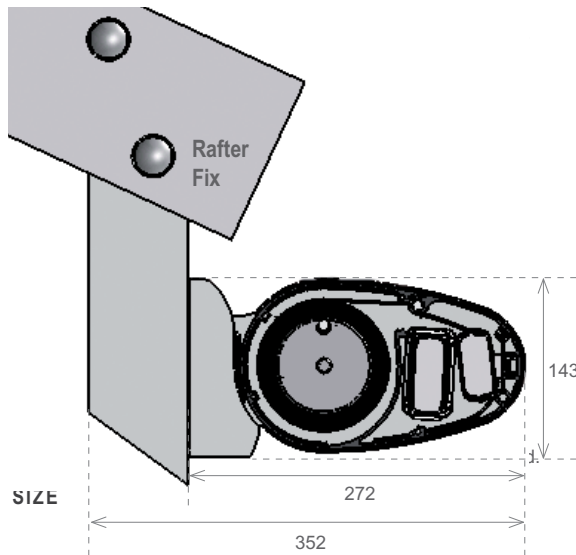
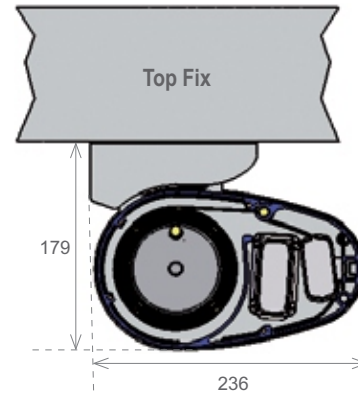
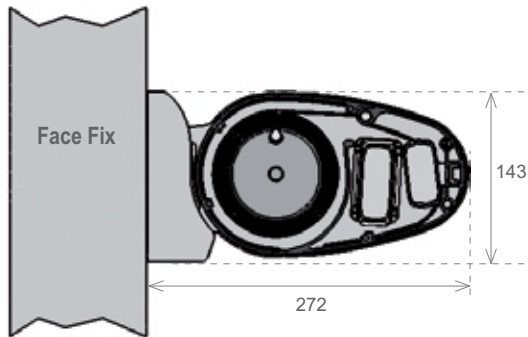

AVAILABLE SIZES

WIDTH Max. 5000mm / Min. 2000mm
 PROJECTION Max. 3000mm / Min. 1500mm

HEADBOX

MATERIAL 6061 grade extruded aluminium
 DIMENSION Height: 143mm top/bottom, Depth: 272mm front/back
 FINISH Standard finish is clear anodised or for custom colour select from Dulux Powder Coat Range

TOP ROLLER

MATERIAL 80mm diameter heavy-duty extruded aluminium

ARM ASSEMBLY

MATERIAL 6061 grade extruded aluminium with 4mm wall thickness
 INTERNAL SPRING ASSEMBLY heavy-duty 8 gauge tensile steel dual spring assembly with dual 3mm PVC coated 316 stainless steel cable providing unparalleled fabric tension

END CAPS

MATERIAL Powder coated cast aluminium providing a minimal profile appearance ideal for reveal installations

FIXING METHODS

TYPE Concealed mounting brackets for face fixing, top fix and rafter brackets are also available

CONTROL OPTIONS

CRANK OPERATION Cast aluminium, 5.1 ratio, Gear 130X with extruded aluminium crank mechanism
 ELECTRIC MOTOR Tubular motor mounted internally within top roller. Aluminium case complete with built-in limit switches. Extensive range of control options available

FABRIC OPTIONS

MARINE GRADE ACRYLIC 100% dope dyed acrylic "Sunacrylic" fibre - Dickson Orchestra available
 SUNSCREEN MESH High tenacity polyester core yarn sunscreen - Soltis 93 (5% openness) Soltis 86 (%15 openness)

COLOUR OPTIONS

Frame Natural Anodised

Optional powder coating to any standard Dulux Colour

Available from:
 Melbourne Shade Systems
 215A Nepean Hwy, Gardenvale, Vic 3185
 Ph: 9596 3333 Fax: 9596 3755
 info@shadesystems.com.au



www.shadesystems.com.au

