



ROLTEX CARETTA CASSETTE FOLDING ARM AWNING SYSTEM

Architect designed, precision German engineering – this ensures maximum technical strength is achieved in combination with a compact and reliable design. The Roltex Caretta is an intelligent choice for complete protection.

Protection – The Roltex Caretta Cassette Folding Arm Awning offers complete protection against harsh ultra violet rays. The unique design allows for up to 14000mm coverage in width and 4000mm in projection making the Caretta ideal for covering larger areas.

Functionality - Designed utilising innovative concealed mounting brackets, ensuring a clean minimal appearance is achieved. Unparalleled lateral stability is achieved thanks to the patented return motion Supa-Kombi Arm Assembly system which ensures maximum fabric tension is maintained in all positions.

Technology - All components are manufactured from heavy-duty drop forged aluminium, our unique cassette utilises high grade 6061 grade extruded aluminium, all components are protected with a durable powder coat finish (Dulux Powder Coat Chart). Our marine grade textiles offer the best compromise between visibility and light transmission, while providing incomparable weather resistance and ease of maintenance.

Quality - Designed, engineered and manufactured in Germany, Certified ISO 9001 and safety tested by German TUV Product Service. Solidux Cassette Folding Arm Awnings Systems are assembled under German quality guidelines and assembly processes in Australia. Tecnic offers our experienced network superior quality and service that you can rely on.



ROLTEX CARETTA CASSETTE FOLDING ARM AWNING SPECIFICATIONS

Please note illustrations are not to scale. All measurements are in millimetres. Please contact your Tecnic representative for additional information.

FIXING METHODS

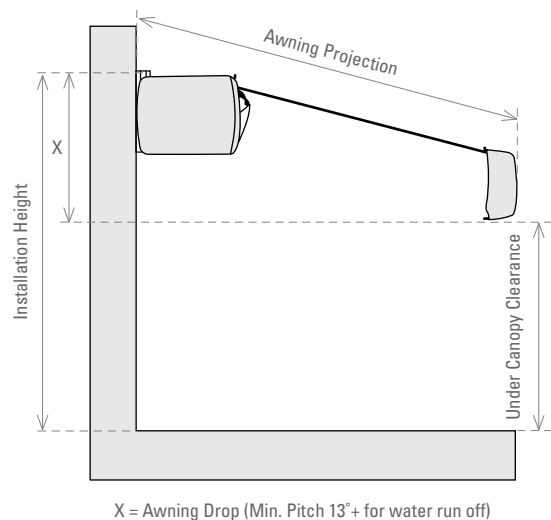
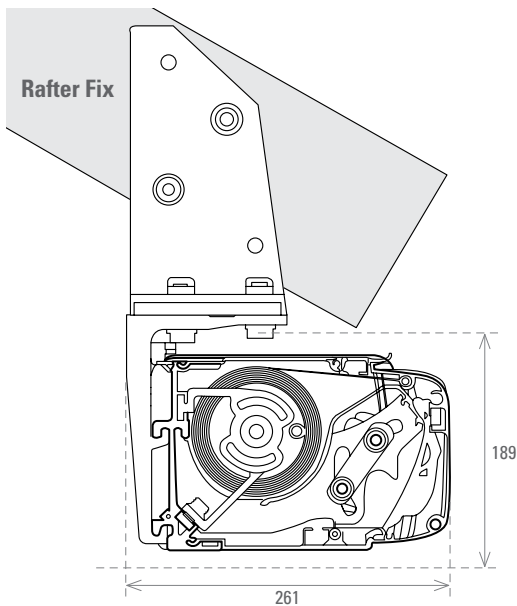
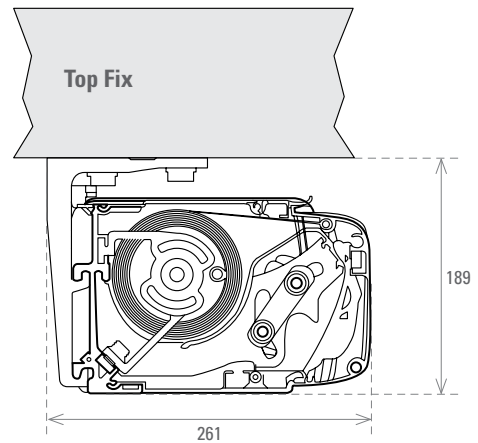
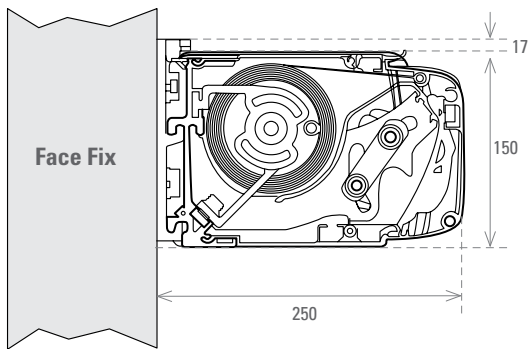

AVAILABLE SIZES

WIDTH	Max. 14000mm (over 7000mm coupled fabric applies) / Min. 2000mm
PROJECTION	Max. 4000mm / Min. 1500mm

HEADBOX

MATERIAL	Powder coated 6061 grade extruded aluminium
DIMENSION	Height: 167mm top/bottom, Depth: 250mm front/back
FINISH	Standard finish is clear anodised or for custom colour select from Dulux Powder Coat Range

TOP ROLLER

MATERIAL	80mm diameter heavy-duty extruded aluminium
----------	---

ARM ASSEMBLY

MATERIAL	Powder coated 6061 grade extruded aluminium with 4mm wall thickness.
INTERNAL SPRING ASSEMBLY	Heavy duty 8 gauge tensile steel dual spring assembly with dual 3mm PVC coated 316 stainless steel cable providing unparalleled fabric tension

END CAPS

MATERIAL	Powder coated cast aluminium providing a minimal profile appearance ideal for reveal installations
----------	--

FIXING METHODS

TYPE	Concealed mounting brackets for face fixing, top fix and rafter brackets are also available
------	---

CONTROL OPTIONS

CRANK OPERATION	Cast aluminium, 5.1 ratio, Gear 130X with extruded aluminium crank mechanism
ELECTRIC MOTOR	Tubular motor mounted internally within top roller. Aluminium case complete with built-in limit switches. Extensive range of control options available

FABRIC OPTIONS

MARINE GRADE ACRYLIC	100% dope dyed acrylic "Sunacrylic" fibre - Dickson Orchestra available
SUNSCREEN MESH	High tenacity polyester core yarn sunscreen - Soltis 93 (5% openness) Soltis 86 (%15 openness)

Available from:
MELBOURNE SHADE SYSTEMS
 215A Nepean Hwy, Gardenvale (Brighton), Vic 3185
 ph: 9596 3333 fax: 9596 3755
 info@shadesystems.com.au

TECNIC